



A METHOD FOR MODELING THE SHOCK OF A RUBBER BUFFER WITH A RIGID BODY

Bozhin Penkov

*Dept of Mechanical Engineering, Gabrovo Technical University,
4 Hadji Dimitar Str., 5300 Gabrovo, Bulgaria
E-mail: penkov@tugab.bg*

Received 3 October 2007; accepted 1 February 2008

Abstract. The aim of this paper is to introduce a robust methodology for the analytical calculation of acceleration by shock of a rigid body with a rubber buffer. It consists of two stages. At first it is necessary to determine some mechanical properties of the viscoelastic material (rubber) by quasistatic tests. The second stage includes shock testing of a rubber buffer and modeling this process with a theoretical model. The proposed methodology provides good accuracy by comparison of the received experimental and theoretical results.

Keywords: rubber buffer; shock, quasistatic and impact testing; modeling shock.

1. Introduction

Buffers are used in cranes and their trolleys as security equipment. When the limit switch has failed, then crane/trolley is hit with the limit support.

The function of buffers is to cushion the shock between them. Rubber is a good material for this purpose, because of the high inner friction of the material, which converts part of the kinetic energy into heat and exchanges it with the environment.

The rubber is a viscoelastic material and its behaviour is not like that of metals. When such a body is loaded (Bland 1960), the strain does not remain constant with the time (Fig. 1). It is changed (increased) and after a long period of time it converges at a limit value ε_0 . This phenomenon is known as creep. In reverse the stress is decreased with the time, what means relaxation. Because of this phenomenon the modeling of the behaviour of a viscoelastic body is different in comparison with metals.

According to Gottenberg and Christensen (1972) – a comparison of the measured and calculated transient response of a viscoelastic solid is not commonly found in the literature.

2. Solving a problem

The modeling of a shock of a rubber buffer with a rigid body includes the following steps:

1. Determining the mechanical characteristics of the viscoelastic material:

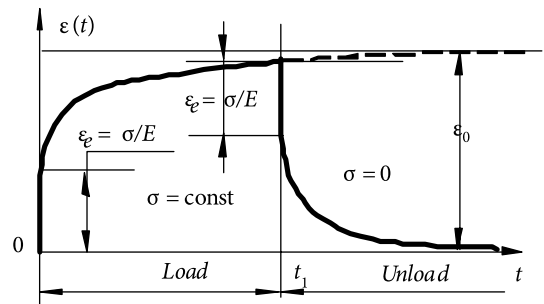

Fig. 1. Development of the process of creep and reverse relaxation

- constructing and producing a test rig for quasistatic study of laboratory samples of rubber;
 - determining the modulus of elasticity and the coefficients of the kernel of creep and relaxation.
2. Modeling the shock of a rubber buffer with a rigid body:
 - constructing and producing a test rig for laboratory study of rubber buffer with a rigid body;
 - creating a mathematical model for shock of a rubber buffer with a rigid body;
 - comparing the experimental data with the theoretical.

When the viscoelastic body is loaded with the stress $\sigma(t)$, the strain is determined using the integral equations of Volterra of second kind (Penkov and Mitev 2006):

$$\varepsilon(t) = \frac{\sigma(t)}{E} + \frac{1}{E} \int_0^t K(t, \tau) \sigma(\tau) d\tau, \quad (1)$$

where $K(t, \tau)$ is the kernel of integral equation (creep kernel).

If the strain $\varepsilon(t)$ is known, the stress $\sigma(t)$ is:

$$\sigma(t) = E\varepsilon(t) - E \int_0^t R(t, \tau) \varepsilon(\tau) d\tau, \quad (2)$$

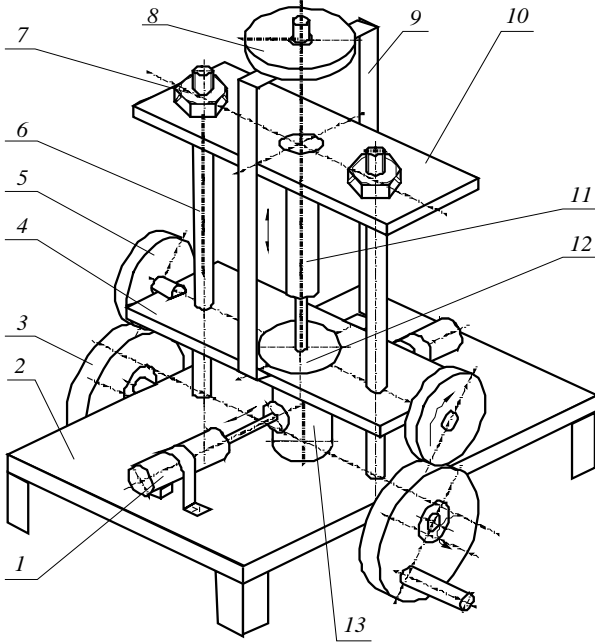

Fig. 2. Test rig for quasistatic testing of pressure:

- 1 – transducers for cross strain; 2 – frame; 3 – lifting cam;
- 4 – movable traverse; 5 – roller; 6 – column; 7 – nut;
- 8 – loading weight; 9 – frame; 10 – fixed (motionless) traverse;
- 11 – transducer for longitudinal strain; 12 – loading disk;
- 13 – laboratory specimen

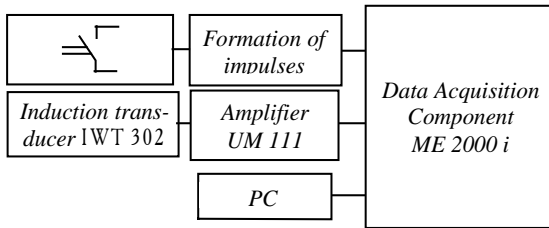

Fig. 3. Structural diagram of measuring system

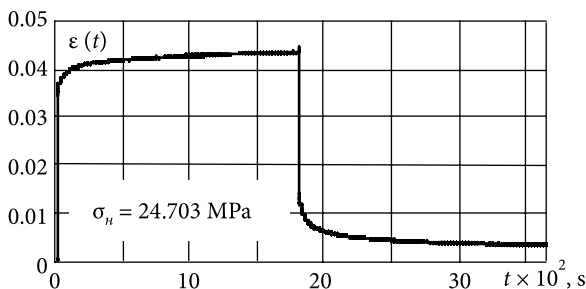

Fig. 4. Experimental results of creep and reverse relaxation

where $R(t, \tau)$ is a function of influence (kernel of relaxation) and it is resolvent of kernel $K(t-\tau)$.

From the theory of the integral equations of Volterra of second type, dependence exists in the form:

$$R(t) - K(t) = \int_0^t K(t-\tau) R(\tau) d\tau; \quad (3)$$

$$K(t) - R(t) = \int_0^t R(t-\tau) K(\tau) d\tau \quad (4)$$

and when for example $K(t)$ is known, $R(t)$ can be determined and vice versa.

When the experiment is carried out when $\sigma = const$ and by differentiation of the equation (1), the rating of creep is obtained to be:

$$K(t) = \frac{E}{\sigma} \frac{d\varepsilon(t)}{dt} \quad (5)$$

and if $\varepsilon = const$, and by differentiation of the equation (2), the rating of relaxation is obtained to be:

$$R(t) = -\frac{1}{E\varepsilon} \frac{d\sigma(t)}{dt}. \quad (6)$$

The quasistatic test (Penkov and Mitev 2005) is conducted using the test rig shown in Fig. 2. Here by changing loading weight 8, different strains are recorded with the induction transducer 11.

The structural diagram of the measuring system is shown in Fig. 3.

Testing laboratory rubber specimen has the following measurements: diameter of $\varnothing 32$ mm and length of 38 mm.

The experimental results of creep are shown in Fig. 4.

The duration of creep is 30 min. and the reverse relaxation – 30 min. respectively. The experiment is conducted at the stress $\sigma_n = 24.703$ MPa and the elastic strain is obtained $\varepsilon_e = 0.0344$. The modulus of elasticity is $E = \sigma/\varepsilon_0 = 7.181$ MPa.

The experimental data of creep (Penkov and Mitev 2005, 2006) are used to determine the coefficients of kernels of creep and relaxation. The kernels used here are with weak singularity:

$$R(t) = Ae^{-\beta t} t^{\alpha-1}; \quad (0 < \alpha < 1, \beta > 0); \quad (7)$$

$$K(t) = \frac{e^{-\beta t}}{t} \sum_{k=1}^{\infty} (-1)^{k+1} \frac{(A\Gamma(\alpha))^k t^{k\alpha}}{\Gamma(k\alpha)}, \quad (8)$$

where: $\Gamma(\alpha) = \int_0^{\infty} t^{\alpha-1} e^{-t} dt$ is a gamma function of Euler;

A, α, β are coefficients of kernels.

From the experimental data the elastic component of strain ε_e is subtracted, i. e. a transformation of the frame of reference with $\tilde{\varepsilon}(t) = \varepsilon(t) - \varepsilon_e$ is made. This data array $\tilde{\varepsilon}(t)$ is differentiated over the time t and the function of the rate of creep $\tilde{K}(t)$ is obtained. For this purpose the following relation is employed:

$$\tilde{K}(t) = \frac{E}{\sigma_n} \frac{d\tilde{\varepsilon}(t)}{dt} \frac{1}{m_t}, \quad (9)$$

where: E is elasticity modulus, Pa; σ_h is pressure of stress, Pa; $m_t = \frac{1}{\text{sample frequency}}$ is scale of time; sample frequency is frequency of discretion of the signal, Hz.

From *MathCAD* the applied pack *MinErr* is employed to determine the coefficients of kernel of creep. The result is: $A = 0.0064285$, $\alpha = 0.85809$, $\beta = 0.034397$ and coefficient of correlation $r = 0.82451$. The experimental and calculated results with the obtained coefficients of the kernel of creep (8) are shown in Fig. 5. The calculated data are in conformity with the experimental data.

For the purpose of the study (Penkov, Petkov and Mitev 2003) of the shock of a rubber buffer with a rigid body, the test rig, shown in Fig. 6 has been designed and developed. The structural diagram of its measuring system is given in Fig. 7. As a basis of this test rig is a reconstruction (modifying) of a Charpy pendulum hammer. Here an additional bed for the fixing of a buffer is fitted, as well as contact, induction, piezo and angle shift transducers. They are employed for the measuring of shock duration time, strain, acceleration and stroke (swing) of the pendulum. The block diagram of the measuring system is shown in Fig. 7.

Fig. 8 shows a record of changes in acceleration during the impact of a pendulum on the rubber buffer. This experiment has been carried out with the buffer P 85 at a declination of a pendulum at an angle of 35.57° . This process can be divided into three parts. The initial stage begins with point 1. At this moment pendulum 6 is released. It goes uniformly accelerating up to the moment of contact with the buffer (the beginning of the impact) – point 2. The initial speed of impact is determined to be $v_0 = 1.9$ m/s and the kinetic energy of pendulum is $E_k = 45,125$ J. In point 2 impact begins and it comes to an end in point 3. The duration of the impact (Fig. 8) $t_s = t_2 - t_3 = 506,2 - 488 = 18,2$ ms is made up of two stages. The first represents deformation (compression) of the buffer, and the second – restoration (recovery) of the buffer. The movement from a point 3 up to point 4 represents free vibration of the pendulum. This movement is related to the third stage of this process. According to the extreme angle which it reaches, the amount of energy which it absorbs is estimated. This period begins when contact between the buffer and a pendulum comes to an end. The pendulum begins the movement in the opposite direction and travels definite distance without achieving initial (starting) position, because part of the kinetic energy of impact is generated as heat as a result of internal friction in the viscoelastic body and after that is exchanged in the environment. The size of this absorption sometimes is estimated with the coefficient of restoration of speed k_r .

Modeling the impact of a rigid body on a rubber buffer is given by Penkov (2006a). In this theoretical model the cross strain of the buffer is taken account of. It brings the following problem:

$$\bar{E} \frac{\partial^2 u}{\partial x^2} + \frac{\mu^2 I_0}{c^2 A} \frac{\partial^4 u}{\partial t^2 \partial x^2} = \frac{1}{c^2} \frac{\partial^2 u}{\partial t^2} \quad (10)$$

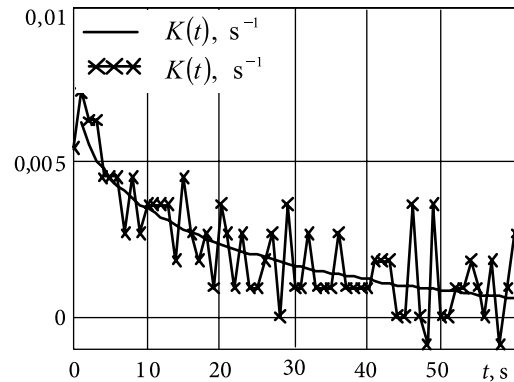

Fig. 5. Function of rate of creep: $\tilde{K}(t)$ – experimental; $K(t)$ – calculated with equation (8)

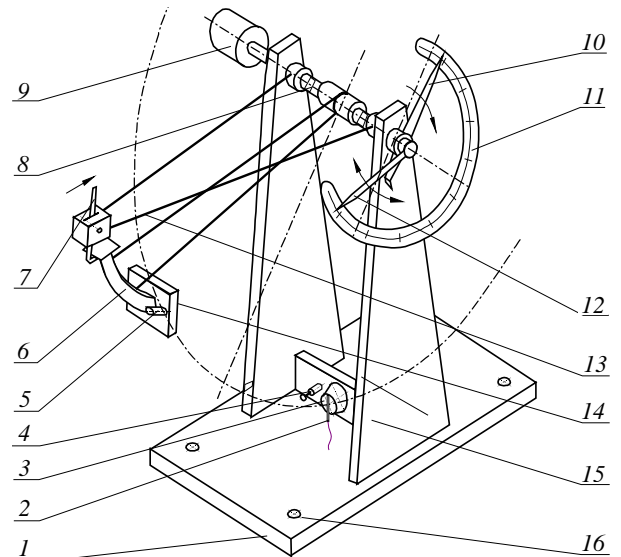

Fig. 6. Testing rig for study of the shock of buffers: 1 – frame; 2 – motionless part of contact transducer; 3 – buffer; 4 – induction transducer; 5 – transducer for acceleration; 6 – striker; 7 – release; 8 – axle; 9 – transducer for angle shift; 10 – pointer for kick; 11 – scale; 12 – pointer for the starting position of pendulum; 13 – arm for the starting position of pendulum; 14 – movable part of contact transducer; 15 – stand; 16 – anchor bolt

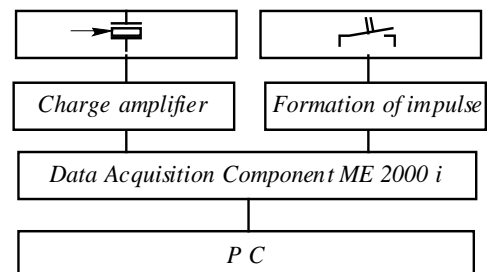

Fig. 7. Structural diagram of measuring system

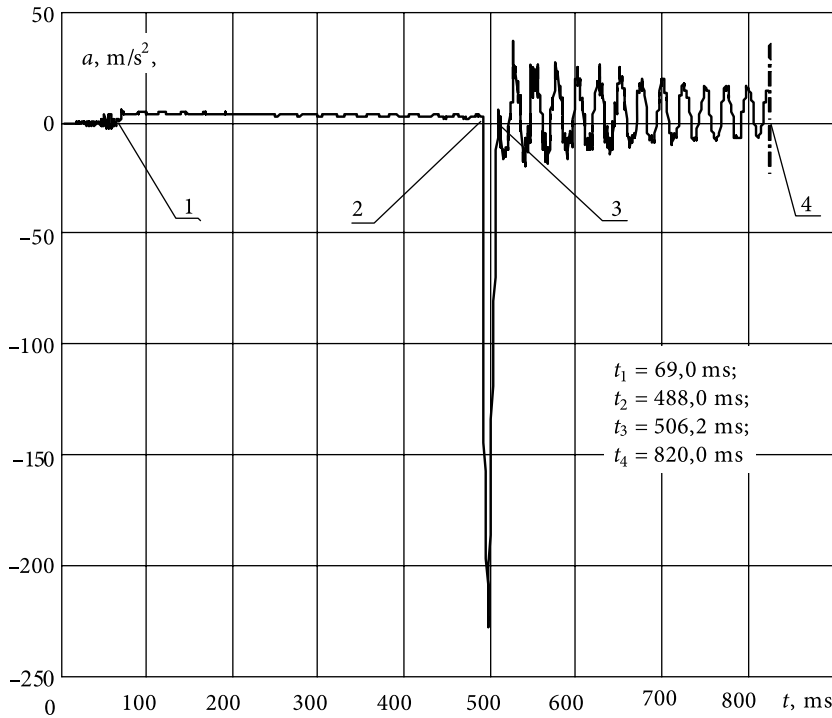

Fig. 8. Changes in the acceleration of a pendulum by shock of the buffer P 85;
 t_1 – release of the pendulum; t_2 – beginning of the shock; t_3 – end of the shock; t_4 – end of the record

by the following initial and boundary conditions:

$$EA\bar{E} \frac{\partial u}{\partial x} \Big|_{x=0} + \mu^2 \rho I_0 \frac{\partial^3 u}{\partial t^2 \partial x} \Big|_{x=0} = -Mg - M \frac{\partial^2 u}{\partial t^2}; \quad (11)$$

$$u|_{t=0} = 0; \quad \frac{\partial u}{\partial t} \Big|_{t=0} = \begin{cases} 0, & 0 < x \leq l, \\ v_0, & x = 0, \end{cases} \quad (12)$$

where \bar{E} is an integral operator of Volterra of the type:

$$\bar{E}(\ast) = (\ast) - \int_0^t R(t - \tau) [\ast(\tau)] d\tau; \quad (13)$$

$$c^2 = \frac{E}{\rho}, \quad (14)$$

where: E is the elasticity modulus; ρ is density of the viscoelastic body (buffer); M is mass of the rigid body; v_0 is initial velocity at the point of impact; A is area of the buffer; l is length of the buffer; $R(t)$ is kernel of relaxation; μ is Poisson's ratio; I_0 is polar moment of inertia of the cross section of the buffer.

The results of the experiment (from point 2 to 3 according to Fig. 8) are shown in Fig. 9. It is seen that the difference between the maximal acceleration is 59 m/s^2 or the error is 20.7 %.

This modeling is not very good. But according to EN 13001-2 Crane safety – General design – Part2: Load effects, the kinetic energy of the shock must be determined with initial velocity $(0.7...1.0) v_0$. A correction is made (Penkov 2006b) and the initial velocity is decreased by 20 %. The result of this calculation is shown in Fig. 10. The curves of experimental a_e and theoretical a_m acceleration show good conformity.

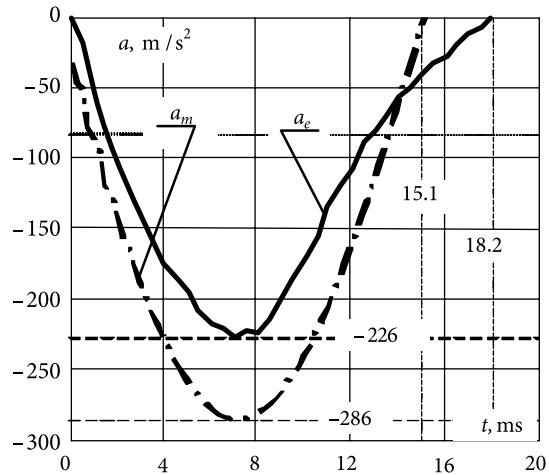

Fig. 9. Comparison between the theoretical a_m and experimental a_e acceleration

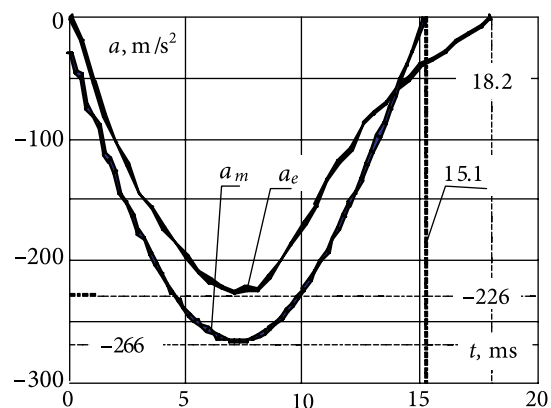

Fig. 10. Comparison between the theoretical a_m and experimental a_e acceleration by $0.8v_0$

3. Conclusions

A method for determining the acceleration is given by impact of a rigid body on a rubber buffer.

It is possible to divide the duration of impact into two stages. The first represents experimental (quasistatic) determination of modulus of elasticity and coefficients of the kernels of creep and relaxation. At the second stage it is necessary to carry out simulation of the process of impact of the buffer on the rigid body.

The result of this simulation is an opportunity for an amendment (decrease) of the initial speed by shock.

A correction has been made as a result of the existing travel resistance by moving of the crane/trolley, which has not been accounted for in the theoretical model (by pendulum this resistance is: friction in bearings, air resistance).

References

- Abrosimov, G. E. 1982. Longitudinal impact of rigid body over viscoelastic road with ultimate length, *Problems of Dynamic and Strength* 40: 80–89 (in Russian).
- Bland, D. R. 1960. *The theory of linear viscoelasticity*. New York. 1200 p.
- Gottenberg, W. G.; Christensen, R. M. 1972. Prediction of the transient response of a linear viscoelastic solid, *Trans. ASME, J. Appl. Mech.* 6: 448–450.
- Lavendel, E. E. 1980. *Applied methods for solving elements of viscoelastic materials*. Riga, Zinatne. 238 p. (in Russian).
- Penkov, B. P.; Mitev, N. A. 2006. Kernels for relaxation and creep – properties and application, *Journal of the Technical University of Plovdiv* 13 (in Bulgarian).
- Penkov, B. P.; Mitev, N. A. 2005. Pseudostatic tests of viscoelastic materials, *Engineering and Electronics*, Sofia, Bulgaria, 90–93 (in Bulgarian).
- Penkov, B. P.; Petkov, S. I.; Mitev, N. A. 2003. Pendulum impact testing machine for buffers, *Journal of the Technical University of Gabrovo* 28: 26–29 (in Bulgarian).
- Penkov, B. P. 2006a. A method for theoretical and experimental study of a shock of rubber buffer with rigid body, *Engineering Technics and Technologies* 1: 17–22 (in Bulgarian).
- Penkov, B. P. 2006b. About initial conditions by modeling of impact over rubber buffer, *Engineering Technics and Technologies* 1: 14–17 (in Bulgarian).